

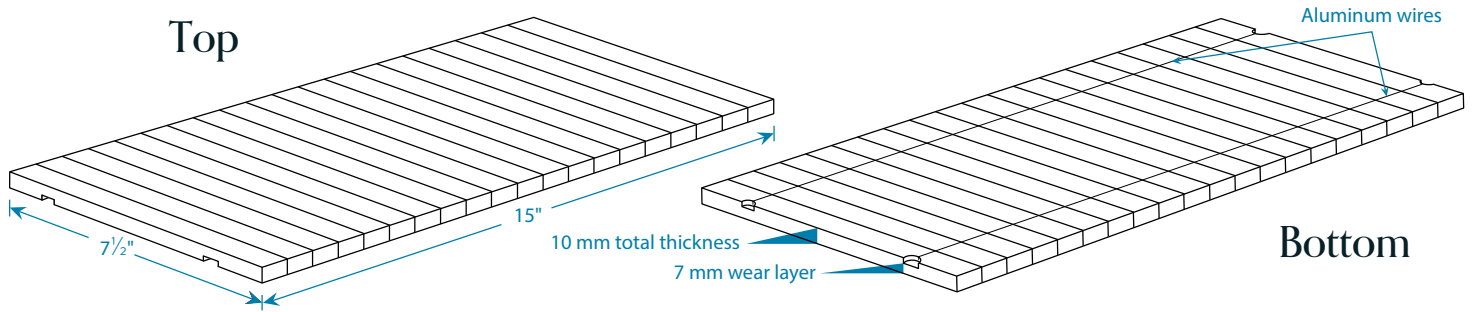

Zena EdgeGrain™

An eco-friendly hardwood option made from 100% Oregon sourced wood that's ideal for both commercial and residential spaces.



Construction: Tiles are composed of individual solid wood strips joined together by two aluminum wires. Tiles are constructed without glue to allow for seasonal movement.

Dimensions: 7½" x 15" x 10 mm

Wear Layer: 7 mm

Sanding Life: 6-8 sandings

Expansion Requirements: ¼" at all vertical obstructions. No expansion gaps required in the floor.

Species | Janka Hardness

Oregon White Oak	1660
Pacific Madrone	1460
Tanoak	1420
Oregon Myrtle	1270
Oregon Ash	1160
Black Walnut	1130
Bigleaf maple	850
Western Larch	830
Western Juniper	680
Douglas-fir	660
Blue Pine	460

Grade: Single grade reflecting the natural variation inherent in each species.

Subfloor Requirements: Surface should be clean and flat per NWFA guidelines.

Installation Methods: Glue down, full trowel spread over subfloor of wood, concrete, radiant, etc.

Patterns: 2:1 ratio provides a multitude of pattern options.

Finish: Tiles are provided unfinished and are ready for site finishing.

Source of Material: Thoughtfully sourced from forests in Oregon.

Sustainability Certifications: FSC® product is available upon request. Declare label coming in 2025.

VOC Emissions: None

Packaging: 0.78 sf/tile, 31.25 sf/bundle, 1,120 sf/pallet

Maintenance: Refer to finish manufacturer's instructions.

Recommended Overage: 5% additional material for on-site grading, trimming, and installation factors. Please note that this can vary by layout.

Warranty: All Zena flooring products are fully warranted against any and all manufacturing defects.

